

Combermere Installation Guide.

CONTOUR
built-in independence

The Combermere is supplied with the following components:-

Bath (LH door - inward opening)
Front panel & Optional Side Panel
Twin Waste kit with Shallow Traps
2 x Wall fixing bracket

Other Items required with contract

Thermostatic Valve TMV 22mm
(MUST BE INSTALLED IN ALL CASES)

Possible additional items :-

Pump and flow switch.

(Refer to Installation notes)

Bath shower mixer.

(Refer to Installation notes.)

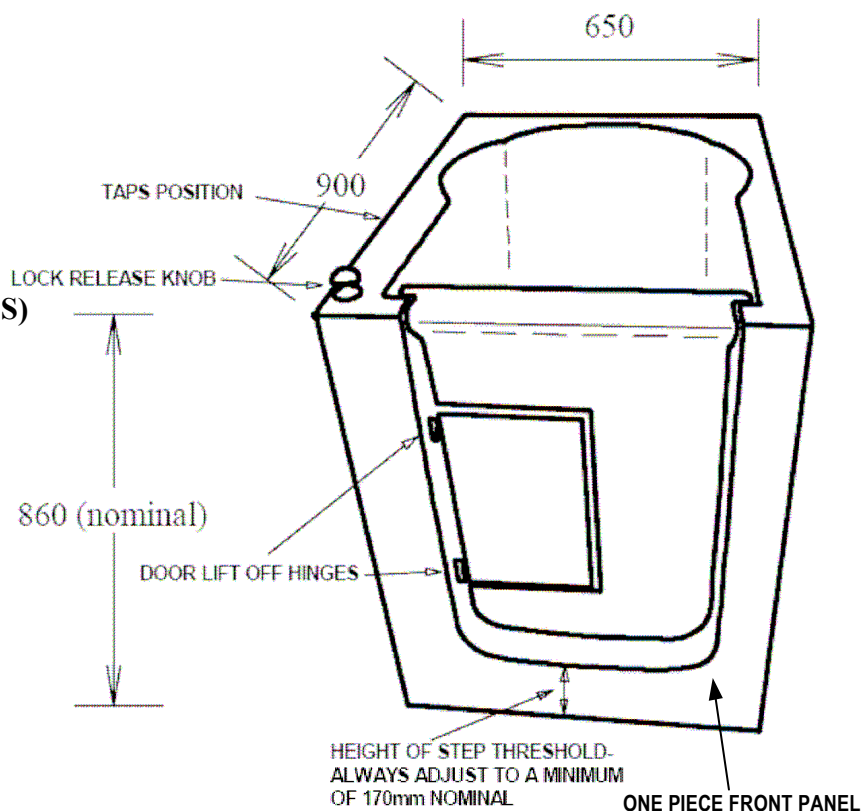

IMPORTANT NOTES

The Combermere is supplied with 4 adjustable feet fitted & has a water capacity of 175 litres (unoccupied) that may require pump assisted taps (minimum 17 litres/min) Bath is filled when user has entered and shut the door consequently the taps must be thermostatically controlled.

Installation is similar as for a standard bath except that twin wastes are supplied to increase drainage rate & to ensure the bath can be drained if one waste fails. The bath should be installed rigidly to ensure there will be no movement or sagging of the floor when bath is used.

Consideration should be given to lowering the wastes below the floor level to keep the step threshold to a minimum to assist customer's ability to step into the bath.

If fitting in an alcove ensure the bath freely goes into position (as sideways pressure can distort the doorway).

The Combermere is manufactured in glass fibre. When handling, proceed with care and caution, in particular the bath edges are more brittle than in acrylic baths.

For ease of manoeuvrability we recommend the door is removed after unpacking the bath. The door is held in place with 'lift-off' hinges on the LHS. Open the door then lift from bath.

Wet Rooms Direct

Telephone: 01685 898110

Email: sales@wetroomsdirect.net Website: www.wetroomsdirect.net

Standard Fitting Guide.

- 1) Lift off door and lay aside.
- 2) Fit the wall fixing brackets to back of back of the bath timber frame for fixing the bath to the wall.
- 3) Drill and affix Taps.
- 4) Fit wastes, overflow and shallow waste traps supplied.
- 5) Place bath in position and adjust to it's minimum height.

Note: It is advisable to fix batten runs on to the floor under the bath feet to avoid extending the legs to far & to ensure feet sit squarely and flat. On a wooden floor batten runs (3"x 2" minimum) should be positioned squarely across the floor boards to spread & support the load.

- 6) Level bath in all planes using the four adjustable feet on the four outer corners and lock the feet.
- 7) Mark wall fixings and plumbing runs.
- 8) Remove bath, drill wall fixings and run plumbing into position.
- 9) Re-position bath and affix to wall and to floor via all four bath feet.
- 10) Connect plumbing. The wastes may be run independently or joined by use of a tee. Refer to fitting guides for the Thermostatic valve and Pump if supplied.
- 11) Re-hang door.
- 12) Test plumbing for leaks.
- 13) Fill bath to maximum and leave for about 30 minutes to test the door seal.
- 14) While the bath seal is tested position and trim to size Front and Side.
- 15) Mark bottom of panels onto floor base. Fix battens along floor behind panels.
- 16) Refit front and side panels. Drill through bottom into batten and top into bath wooden frame. Affix panels using screws and caps. Do not use Silicone sealant as this prevents service access.
- 17) Finally drain bath and Leave the Door Open (Door should not be locked when not in use to prevent over compression of seal)
- 18) Instruct customer on the use of the bath.

◆ **Refer to 'Operating/Care and Maintenance Instructions' and leave copy with customer.**

◆ **Do not leave door in locked position on completion. Advise customer that the door should be left unlocked when not in use in order to preserve the seal.**

July 2013

Wet Rooms Direct

Telephone: 01685 898110

Email: sales@wetroomsdirect.net Website: www.wetroomsdirect.net

THE COMBERMERE BATH

IMPORTANT INSTRUCTIONS FOR CUSTOMER

PLEASE READ CAREFULLY AND RETAIN FOR FURTHER USE.
IMPROPER USE OR CARE CAN INVALIDATE THE WARRANTY.

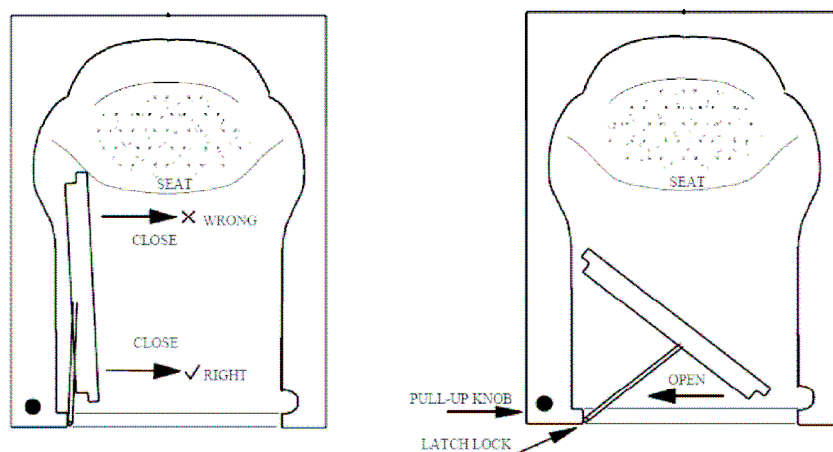

OPERATING INSTRUCTIONS

The Combermere bath features a 2-part folding door to allow for easier access. A latch lock and bolt are located on the left and right hand side of the doorway respectively. Simply 'slam shut' door to close and lock into position. Always keep the door unlocked when not in use to prevent wear out of the seal.

1. Prior to entering bath push door inwards to far left hand side.
2. In a standing position in bath shut door by pulling gently from nearside of door only (do not pull from far side as door will jam). As door approaches closed position push outwards to engage latch lock and secure door.

Now be seated. Bath is ready for use.

3. After bathing, remain seated whilst all the water is drained on release of the 2 wastes.
4. Pull on the lock knob in a standing position to release and open door.
5. Exit bath and leave the door open when not in use to preserve the seal .

****IT IS BEST TO HANDLE DOOR JUST OFF CENTRE ON NON-HINGE SIDE ****

**** NEVER ATTEMPT TO OPEN DOOR WHEN BATH IS FILLED WITH WATER ****

**** DO NOT LEAN ON DOOR OR USE FOR SUPPORT ****

CARE AND MAINTENANCE

The Combermere Bath is manufactured to a very high standard in G.R.P. (Reinforced Plastic) to ensure its durability and appearance is maintained over many years of use. It has a robust, smooth and warm surface which is non-porous, resistant to dirt and bacteria and easy to clean and maintain.

This bath will give many years of service and continue to look good if cleaned correctly and treated with care.

CLEANING

1. As with standard baths, cleaning will vary subject to the scale residue dependant on the hard or soft water level. In soft water areas, wash down with warm water and detergent applied with a soft cloth or sponge. In hard water areas, non-abrasive or mild acid cleansers can be used. Clean regularly followed by wiping with a dry soft cloth.

Widely available proprietary plastic/enamel bath cleansers are ideal cleaning agents which offer the advantage of a polished shine without rubbing down.

For the extra sparkle, and to further preserve the surface, the Bath can be gently polished occasionally. Beeswax and Brasso (Brass Polish) are suitable for this purpose. Polishing the anti-slip base should be treated with caution so as not to diminish its effectiveness.

2. The stainless steel lock receiver on outer face of door can be polished occasionally with a stainless steel polish to ensure it does not discolour. It is recommended the latch lock is lubricated on average once a year subject to the chlorine content in the water. A lubricant such as “WD 40” or “3 in 1 oil” would be adequate.
3. The white silicone seal along bath door sides should be cleaned occasionally. Use detergent and warm water applied with a sponge or soft cloth. Apply gently and refrain from excessive rubbing.
4. Ideally all chrome or gold plated furniture should be wiped down dry after use. Clean with soapy water and buff with a dry soft cloth. Note: Surfaces can easily be damaged with acid/abrasive cleaners or with a rough sponge.

CAUTION

- **DO NOT LOCK THE DOOR WHEN BATH IS NOT IN USE AS THIS WILL WEAR OUT THE SEAL.**
- **KEEP THE WHITE SILICONE SEAL FREE OF ANY BUILD UP OF DEPOSITS. CLEAN GENTLY AND AVOID UNNECESSARY HANDLING.**
- **DO NOT APPLY ANY UNDUE FORCE TO THE BATH DOOR. HANDLE GENTLY.**

